



Air Atomising Products

# Swirl-Air<sup>®</sup> Nozzles

Product Guide



Swirl-Air® Product Introduction

# Swirl-Air® Nozzles



# Delavan Spray Technologies Continually meeting the challenges of new industries and markets

**Delavan Spray Technologies**, part of the Goodrich Corporation, is a world leader in the design and manufacture of high quality spray nozzles and fluid handling systems. Since the company was founded back in 1935, the Delavan name has always stood for quality, flexibility and reliability.

The **Delavan Swirl-Air**<sup>®</sup> range of spray nozzles, based on aerospace technology and developed within our Gas Turbine Division was designed to maximise hydraulic and pneumatic energy to atomize liquids at relatively low pressures. Originally designed for use in evaporative cooling, spray drying and combustion, they have since been used in many other industrial applications from Food to Steel production. Different spray angles are available; flow rates can be changed by adjusting air and liquid pressure and the degree of atomization controlled by changes in the air-to-liquid volume ratio.

Two installation configurations are available. In the right angle nozzle, atomizing air enters the side and the liquid enters axially in the back. With the in-line nozzle, concentric piping is used with the liquid in the centre and atomising air entering around the outside. Concentric pipe adapter assemblies are optional and are not included with the nozzle assembly as standard.

Our specialist design teams can also provide customised designs for your own applications, contact our sales team for more information.

Contact our Helpline or your local distributor for further information  
Tel: +44 (151) 424 6821 or inside USA Toll Free: 1-800 Delavan  
E-mail: [delavanspray@goodrich.com](mailto:delavanspray@goodrich.com) or [sales@delavan.co.uk](mailto:sales@delavan.co.uk)

# Swirl-Air® Nozzles

## Nozzle Flow Diagram

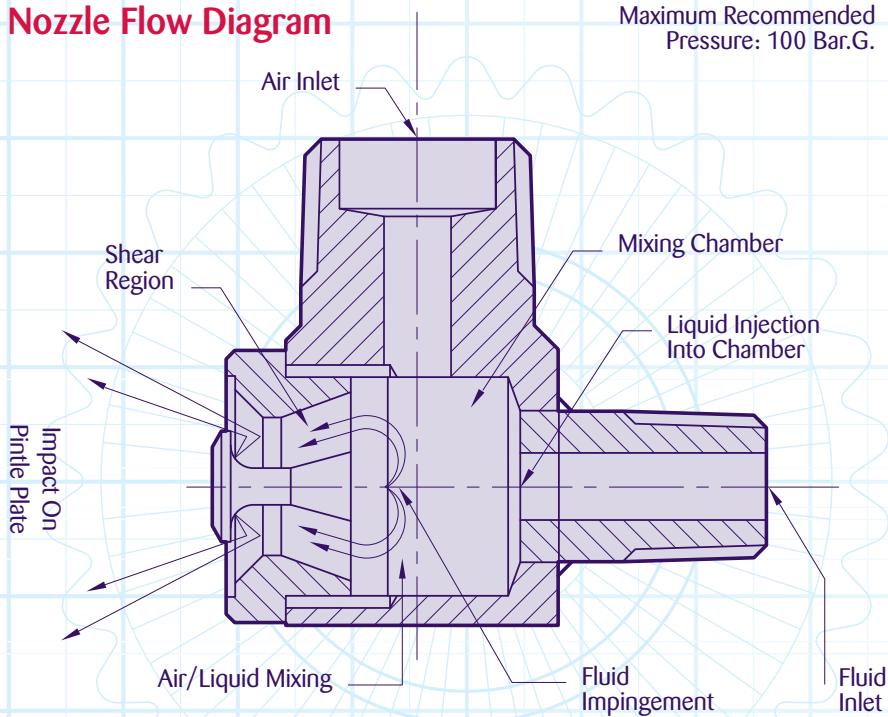

## Evaporative Cooling Water Injection Rates vs Gas Inlet/Outlet Temperatures

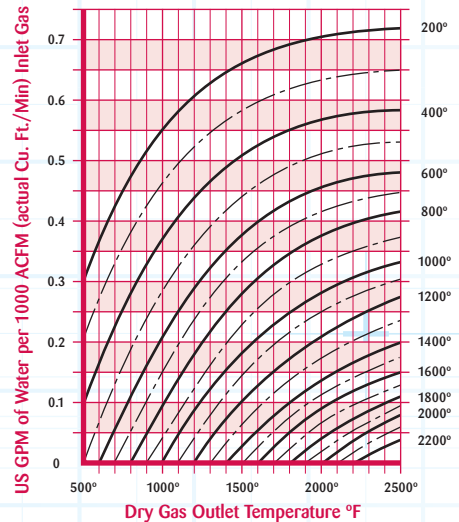

Example: 1700°F dry inlet gas to be cooled to 800°F outlet temperature requires 0.32 US GPM water injection per 1000 CFM of inlet gas.

## How The Nozzle Works

Liquid enters the nozzle axially, coming in contact with a tangentially introduced stream of air/gas or steam in the nozzle mixing chamber. The liquid impinges on the pintle plate and the interaction of gas and liquid creates extreme turbulence in the chamber. The swirling liquid, seeking an exit, impinges against the walls and distributor plate and then flows through the venturi-shaped orifice, where the droplets are exposed to extreme shear forces before impinging against a circular deflector ring and leaving the nozzle as a finely atomized spray cone.

The deflector ring is held in position by a cone projecting from the distributor plate. This method eliminates struts that could interfere with the spray pattern. The progressive application of shear and inertial forces within the nozzle provide for a relatively high nozzle efficiency.

## Construction & Materials

The nozzles have a two piece construction; the nozzle body, plus an integral deflector ring and cap that is easily removable without disturbing pipe connections. There are no external struts or supports to interfere with spray patterns. Standard configurations are available in 316L Stainless Steel and 440 Stainless Steel. Other materials such as Hastelloy C276 and Inconel 600 are available – please contact the Sales & Marketing Team or your local Distributor for further details.

## Swirl-Air® Advantages

- ▶ Large fluid passages to easily accommodate coarse particles
- ▶ No external struts to interfere with the spray pattern
- ▶ Variations in spray angle via interchangeable nozzle caps – produces wider spray patterns than most two-fluid atomisers
- ▶ Nozzle design provides vortex mixing, primary impingement, fluid distribution, and external impact for fine atomisation
- ▶ Air consumption and power requirements are relatively low, permitting specification of smaller air compressors
- ▶ Good atomisation over wide range of turn-down ratios
- ▶ Droplet size control provided by applying only minor changes in air/liquid pressure

## Applications

- ▶ Gas Cooling/Conditioning
- ▶ Humidification
- ▶ Coating Applications
- ▶ Furnace Temperature Control
- ▶ Spray Drying
- ▶ Process Control (eg Acid Sprays)
- ▶ Combustion
- ▶ Dust Suppression
- ▶ Odour Control
- ▶ Spray Sanitation/Fumigation of Food Production Areas
- ▶ Special Effects (eg Fog Production on Film Sets)
- ▶ Low Volume/High Pressure, Fine Atomisation for Fire Protection Systems
- ▶ Fume Scrubbing
- ▶ Steam Desuperheating
- ▶ Mould Cooling
- ▶ Oven Humidity Control

## Spray Characteristics

Air/Gas (or steam) is introduced tangentially into the nozzle chamber in low pressure region of the swirling liquid, creating extreme turbulence and primary atomization. As liquid leaves the orifice, it impinges against the deflector ring which serves a dual purpose; close control of spray angle and break up of the spray into even finer droplets (secondary atomization).

Eight sizes of nozzle are available covering flow rates from 1-2400 GPH. Nominal spray angles of 50°, 75° and 100° can be attained by the specification of interchangeable nozzle caps. Contact the factory for special spray angles from 25° up to 160°.

The nozzle has demonstrated the capability of achieving mean droplet diameters in the 50-100 micron range at low air pressures and flows. When using dry steam instead of air, the steam pressure should be approximately four times greater than air pressure to achieve the same spray characteristics. Comparable atomization in a hydraulic nozzle would usually require very high pressures. Degree of atomization is also variable by controlling the volume ratio of air to liquid.

As mentioned, droplet size may be changed by minor changes in air pressure. However, if air pressure is set initially, and it is necessary to modulate the liquid flow, the air differential pressure and flowrate will automatically respond in such a way that the quality of atomization remains nearly constant. In some applications, this can result in a saving through the elimination of air valving and controls.

## Typical Nozzle Installations

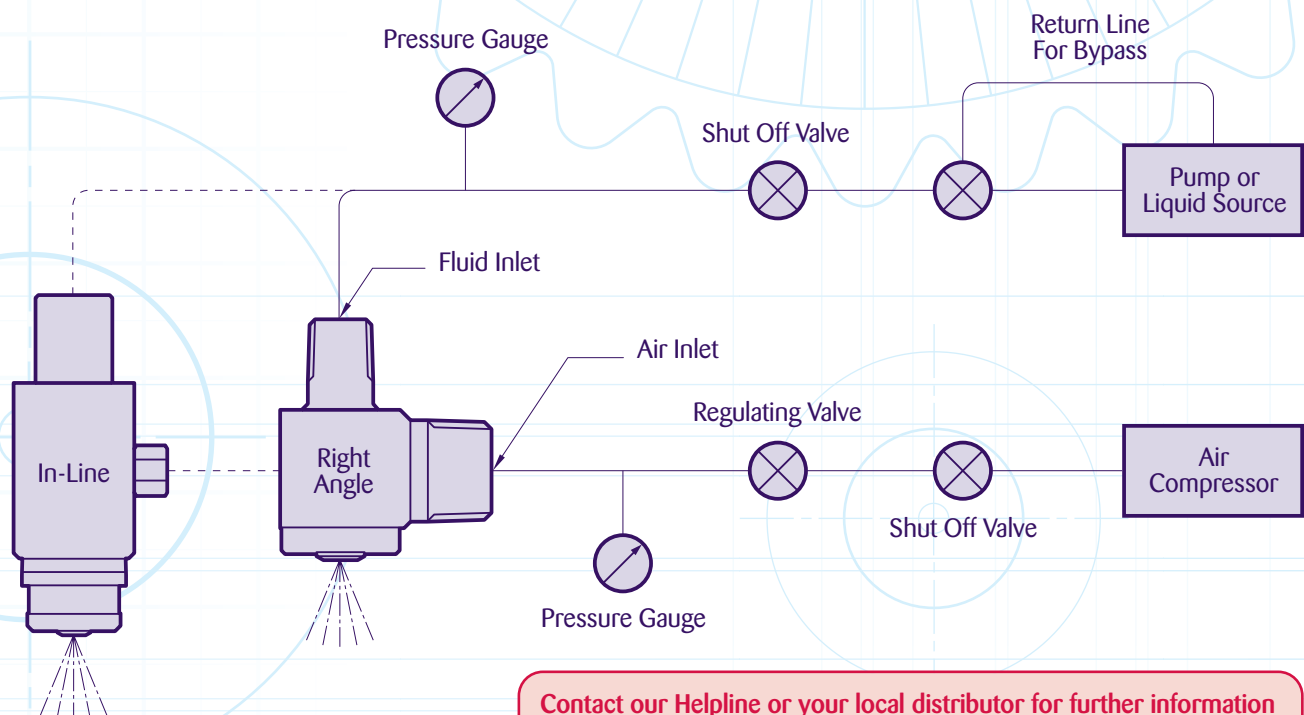

Contact our Helpline or your local distributor for further information  
Tel: +44 (151) 424 6821 or inside USA Toll Free: 1-800 Delavan  
E-mail: delavanspray@goodrich.com or sales@delavan.co.uk

# Right Angle Nozzles

## Standard Version

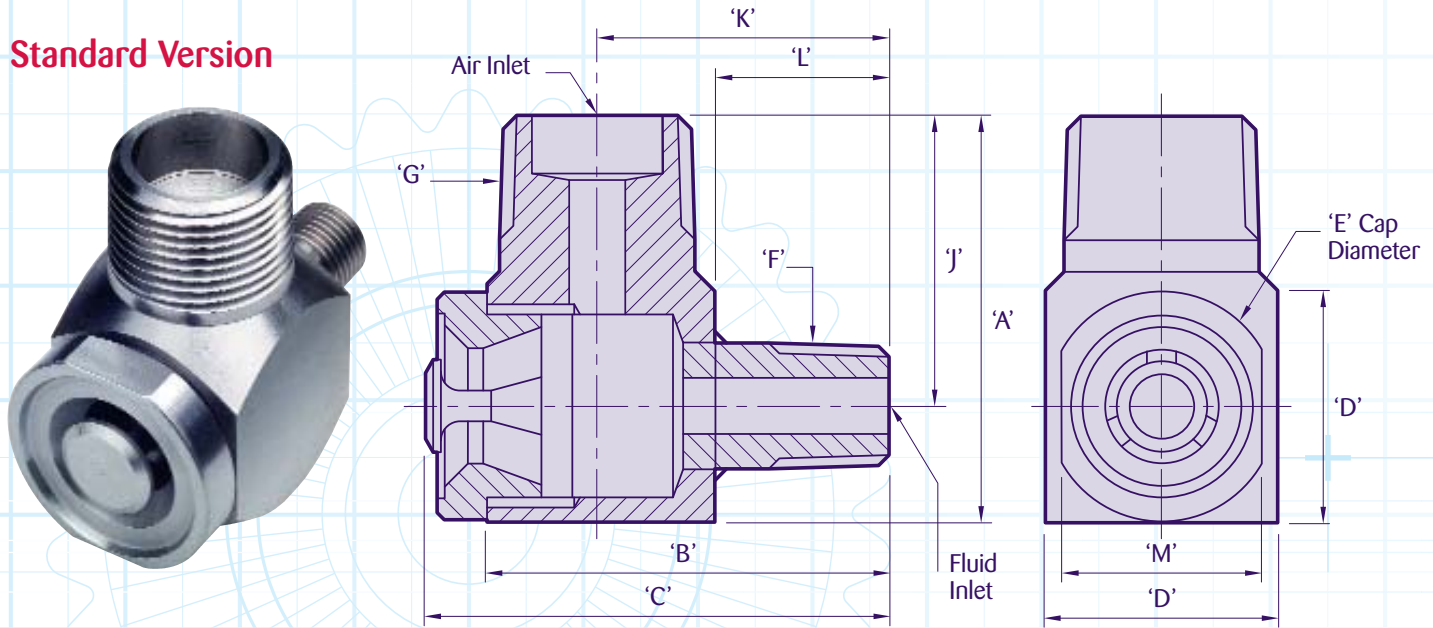

Right Angle Nozzle Assembly Dimensions (inches/mm)

Dimension	45506	31618	31325	31693	31694	32163
A	2.63/66.7	2.13/54	1.75/44.5	1.37/34.9	1.13/28.6	1.13/28.6
B	2.22/56.4	2.04/51.8	1.83/46.4	1.5/38.1	1.37/34.9	1.37/34.9
C	2.54/64.6	2.33/59.2	2.11/53.7	1.67/42.3	1.52/38.5	1.52/38.5
D	1.5/38.1	1.25/31.8	1/25.4	0.75/19	0.63/15.9	0.63/15.9
E	1.63/41.3	1.37/34.7	1.11/28.3	0.87/22	0.74/18.8	0.74/18.8
F (NPT)	— 1/8"-18	— 1/8"-18	— 1/8"-18	— 1/8"-27	— 1/8"-27	— 1/8"-27
G (NPT)	— 3/8"-14	— 3/8"-14	— 1/2"-14	— 3/8"-18	— 1/2"-18	— 1/2"-18
J	1.87/47.6	1.5/38.1	1.25/31.8	1/25.4	20.6	20.6
K	1.5/38.1	1.41/35.9	1.33/33.7	1.13/28.6	1.06/27	1.06/27
L	0.75/19	0.79/20	0.83/21	0.75/19.1	0.75/19.1	0.75/19.1
M	1.44/36.5	1.25/31.8	1/25.4	0.75/19.1	0.63/15.9	0.63/15.9

Right Angle Nozzle Sizing Chart

Nominal Flow USGPM/LPM	Nozzle Assembly Reference Number	Dash Numbers For Material and Nominal Spray Angle				Cap Assembly	
		316 SS	440 HSS	Angle (°)	Min. Passage (inches/mm)	316 SS	440 HSS
25/94	45506	-2	—	50 (40-60)	0.24/6.1	707-97	—
		-1	—	75 (65-85)	0.19/4.8	707-96	—
		-3	—	100 (90-110)	0.15/3.8	707-98	—
15/56	31618	-2	-5	50 (40-60)	0.240/6.1	707-11	707-26
		-1	-4	75 (65-85)	0.14/3.6	707-10	707-25
		-3	-6	100 (90-100)	0.11/2.8	707-12	707-27
10/37	31325	-2	-5	50 (40-60)	0.09/2.5	707-8	707-23
		-1	-4	75 (65-85)	0.08/2.1	707-7	707-22
		-3	-6	100 (90-100)	0.06/1.6	707-9	707-24
4/15	31693	-2	-5	50 (40-60)	0.07/1.7	707-5	707-20
		-1	-4	75 (65-85)	0.07/1.7	707-4	707-19
		-3	-6	100 (90-100)	0.07/1.7	707-6	707-21
2.5/9.5	31694	-2	-5	50 (40-60)	0.05/1.3	707-2	707-17
		-1	-4	75 (65-85)	0.05/1.3	707-1	707-16
		-3	-6	100 (90-100)	0.05/1.3	707-3	707-18
1/3.8	32163	-11	—	50 (40-60)	0.03/0.64	707-93	—
		-2	—	75 (65-85)	0.03/0.64	707-13	—
		-7	—	100 (90-100)	0.03/0.64	707-29	—
0.2/0.8	32163	-10	—	50 (40-60)	0.03/0.64	707-93	—
		-1	—	75 (65-85)	0.03/0.64	707-13	—
		-8	—	100 (90-100)	0.03/0.64	707-29	—

Higher flow rates can be achieved by increasing pressure.

## Concentric Inlet Version

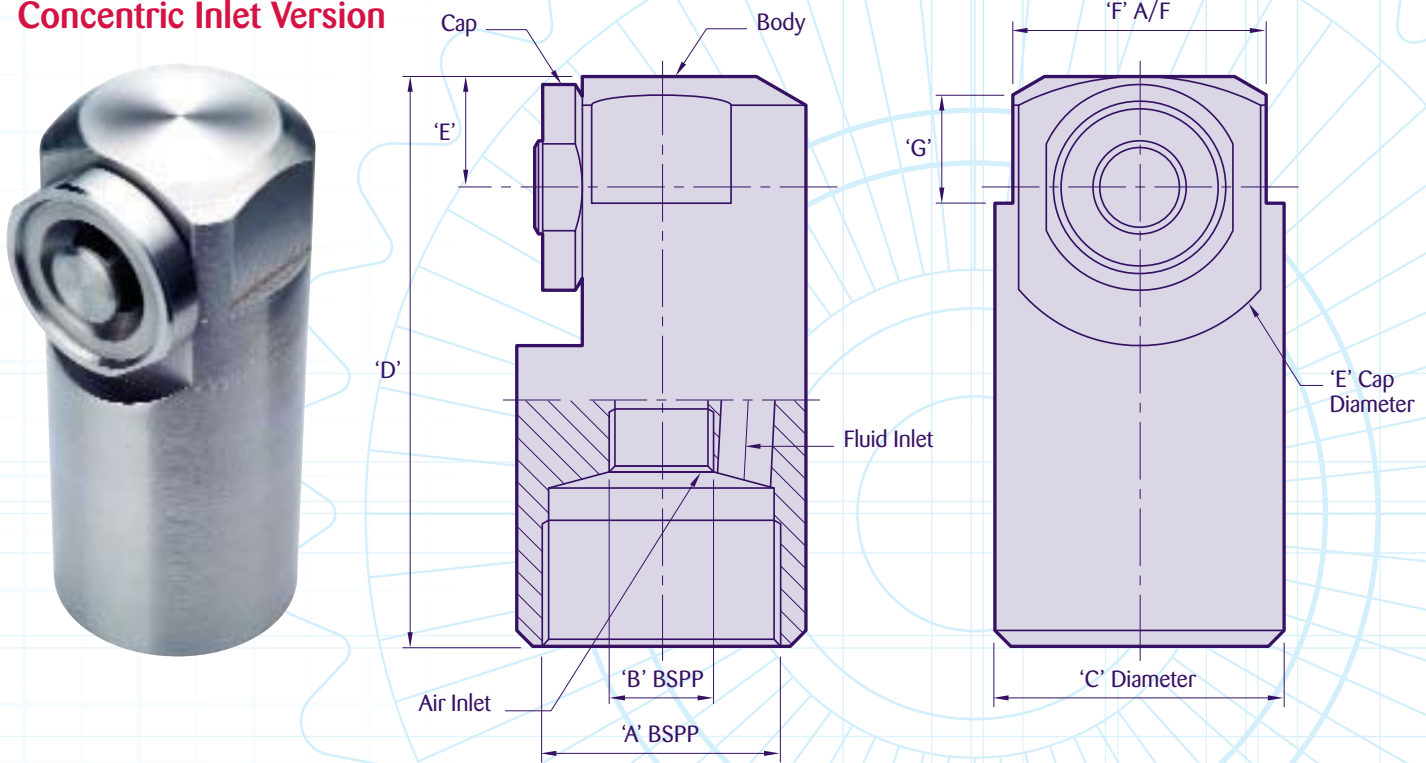

Concentric Inlet Nozzle Assembly Dimensions (inches/mm)

Dimension	W12216	W12217	W12218
A	1" BSPP	1½" BSPP	2" BSPP
B	¼" BSPP	½" BSPP	¾" BSPP
C	1.77/44.4	2.28/58	2.76/70
D	3.88/98.5	4.5/114.5	5.63/143
E	0.75/19	0.87/22	1/25.5
F (A/F)	1.5/38	2/51	2.38/60.5
G	0.87/22	1/25.5	1.25/32
Equivalent Nozzle	31618	45506	Special

Right Angle Concentric Inlet Nozzle Sizing Chart

Nominal Flow USGPM/LPM	Nozzle Assembly Ref Number	316 SS	Angle (°)	Cap Assy 316 SS
42/159	W12218	-3	100 (90-110)	W12133
94/25	W12217	-1	50 (40-60)	707-097
		-2	75 (65-85)	707-096
		-3	100 (90-110)	707-098
15/56	W12216	-2	50 (40-60)	707-11
		-1	75 (65-85)	707-10
		-3	100 (90-110)	707-12
10/38	W21057	-2	50 (40-60)	707-8
		-1	75 (65-85)	707-9
		-3	100 (90-110)	707-9
4/15	W20890	-2	50 (40-60)	707-5
		-1	75 (65-85)	707-4
		-3	100 (90-110)	707-6

\* Higher flow rates can be achieved by increasing pressure.

## Product Application

The version of the **Swirl-Air® Nozzle** with concentric inlets would typically be used in vessels containing hazardous environments, where the spray cone needs to be located at right angles to the feed pipe.

The standard thread for the **Swirl-Air® Nozzle** is NPT, however BSPT is available on request.

Contact our Helpline or your local distributor for further information  
Tel: +44 (151) 424 6821 or inside USA Toll Free: 1-800 Delavan  
E-mail: delavanspray@goodrich.com or sales@delavan.co.uk





Right Angle Nozzle P/N 31693 4 USGPM/15 LPM Max Flow

Liquid Flow	Liquid Pressure (PSI)/Air Consumption (SCFM) at these Air Pressures (PSI)									
	30 PSI		40 PSI		50 PSI		80 PSI		100 PSI	
	USGPM	PSI	SCFM	PSI	SCFM	PSI	SCFM	PSI	SCFM	PSI
0.33	15	16	21	20	26	24	43	36	55	44
0.50	16	15	23	19	29	23	47	35	59	43
0.66	18	14	25	18	31	22	50	34	63	42
1	21	13	28	16	35	20	56	32	69	40
2	28	8	36	11	45	15	68	26	85	33
3	33	5	42	7	51	10	78	19	95	24
3.5	36	3	45	6	54	8	81	16	99	22
4	39	2	48	5	57	7	84	14	103	19

Concentric Inlet Version P/N W20890

Liquid Flow	Liquid Pressure (BAR)/Air Consumption (M3/MIN) at these Air Pressures (BAR)									
	2 BAR		2.8 BAR		3.5 BAR		5.5 BAR		7 BAR	
	LPM	BAR	M3/MIN	BAR	M3/MIN	BAR	M3/MIN	BAR	M3/MIN	BAR
1	1.03	0.45	1.45	0.57	1.79	0.68	2.97	1.02	3.79	1.25
2	1.10	0.42	1.59	0.54	2.00	0.65	3.24	0.99	4.07	1.22
3	1.24	0.40	1.72	0.51	2.14	0.62	3.45	0.96	4.34	1.19
4	1.45	0.37	1.93	0.45	2.41	0.57	3.86	0.91	4.76	1.13
8	1.93	0.23	2.48	0.31	3.10	0.42	4.69	0.74	5.86	0.93
11	2.28	0.14	2.90	0.20	3.52	0.28	5.38	0.54	6.55	0.68
13	2.48	0.08	3.10	0.17	3.72	0.23	5.59	0.45	6.83	0.62
15	2.69	0.06	3.31	0.14	3.93	0.20	5.79	0.40	7.10	0.54

Right Angle Nozzle P/N 31694 2.5 USGPM/9.5 LPM Max Flow

Liquid Flow	Liquid Pressure (PSI)/Air Consumption (SCFM) at these Air Pressures (PSI)									
	30 PSI		40 PSI		50 PSI		80 PSI		100 PSI	
	USGPM	PSI	SCFM	PSI	SCFM	PSI	SCFM	PSI	SCFM	PSI
0.33	18	9.0	25	11.5	31	14	51	21.5	59	26.5
0.5	20	8.0	27	10.5	34	13	54	20.5	65	25.5
0.66	22	7.5	29	10	36	12.5	57	20	69	25
1	24	6.5	32	8.5	40	11	63	18	76	22.5
1.5	28	4.5	36	6.3	44	9	69	15	86	19.5
2	30	5	39	4	48	6	75	12	92	16
2.5	32	1.5	41	3	50	4.5	78	9	97	12

Liquid Flow	Liquid Pressure (BAR)/Air Consumption (M3/MIN) at these Air Pressures (BAR)									
	2 BAR		2.8 BAR		3.5 BAR		5.5 BAR		7 BAR	
	LPM	BAR	M3/MIN	BAR	M3/MIN	BAR	M3/MIN	BAR	M3/MIN	BAR
1	1.24	0.25	1.72	0.33	2.14	0.40	3.52	0.61	4.07	0.75
2	1.38	0.23	1.86	0.30	2.34	0.37	3.72	0.58	4.48	0.72
3	1.52	0.21	2	0.28	2.48	0.35	3.93	0.57	4.76	0.71
4	1.66	0.18	2.21	0.24	2.76	0.31	4.34	0.51	5.24	0.64
6	1.93	0.13	2.48	0.18	3.03	0.25	4.76	0.42	5.93	0.55
8	2.07	0.14	2.69	0.11	3.31	0.17	5.17	0.34	6.34	0.45
9.5	2.21	0.04	2.83	0.08	3.45	0.13	5.38	0.25	6.69	0.34

Right Angle Nozzle P/N 32163 1 USGPM/3.8 LPM Max Flow

Liquid Flow	Liquid Pressure (PSI)/Air Consumption (SCFM) at these Air Pressures (PSI)									
	30 PSI		40 PSI		50 PSI		80 PSI		100 PSI	
	USGPM	PSI	SCFM	PSI	SCFM	PSI	SCFM	PSI	SCFM	PSI
0.2	26.8	4	36	5	45.2	6	73	9	90.8	11.5
0.3	27.2	3	36.8	4.5	45.6	5.5	74	8.5	93	10.5
0.4	27.8	2.8	37.2	4	46.6	4.5	75.4	7.5	94.6	9.5
0.5	28	2.5	37.8	3	47.4	4	76	7	95.2	8.5
0.6	28.6	2	38	2.5	47.8	3.5	77.2	6	97	7.5
0.7	28.8	1.5	38.4	2	48.2	3	78	5	97.2	7
0.8	29	1.2	38.6	1.8	48.6	2.5	78.6	4.5	98	6
0.9	29.2	1	39	1.5	48.8	2	79	4	98.6	5.5
1	29.4	-	39.2	1.2	49	1.8	79.2	3.5	99.2	5

Liquid Flow	Liquid Pressure (BAR)/Air Consumption (M3/MIN) at these Air Pressures (BAR)									
	2 BAR		2.8 BAR		3.5 BAR		5.5 BAR		7 BAR	
	LPM	BAR	M3/MIN	BAR	M3/MIN	BAR	M3/MIN	BAR	M3/MIN	BAR
0.76	1.85	0.11	2.48	0.14	3.12	0.17	5.03	0.25	6.26	0.33
1.14	1.88	0.08	2.54	0.13	3.14	0.16	5.10	0.24	6.41	0.30
1.52	1.92	0.08	2.57	0.11	3.21	0.13	5.20	0.21	6.52	0.27
1.89	1.93	0.07	2.61	0.08	3.27	0.11	5.24	0.20	6.57	0.24
2.27	1.97	0.06	2.62	0.07	3.30	0.10	5.32	0.17	6.69	0.21
2.65	1.99	0.04	2.65	0.06	3.32	0.08	5.38	0.14	6.70	0.20
3.03	2	0.03	2.66	0.05	3.35	0.07	5.42	0.13	6.76	0.17
3.41	2.01	0.03	2.69	0.04	3.37	0.06	5.45	0.11	6.8	0.16
3.79	2.03	0	2.7	0.03	3.38	0.05	5.46	0.10	6.84	0.14

Right Angle Nozzle P/N 32163 0.2 USGPM/0.8 LPM Max Flow

Liquid Flow	Liquid Pressure (PSI)/Air Consumption (SCFM) at these Air Pressures (PSI)									
	50 PSI		60 PSI		70 PSI		80 PSI		100 PSI	
	USGPM	PSI	SCFM	PSI	SCFM	PSI	SCFM	PSI	SCFM	PSI
0.02	7.5	3	9.5	3.5	11.5	4	13.5	4.5	17.5	5.5
0.05	9	3	11.5	3.5	13.5	4	15.5	4.5	19.5	5.5
0.1	13	3	16	3.5	19	4	21.5	4.5	27	5.5
0.15	16.5	3	20	3.5	23.5	4	27	4.5	33.5	5
0.2	20.5	3	24.5	3.5	28.5	3.8	32.5	4	40.5	5
0.3	25	3	29.5	3.3	34	3.5	38.5	4	47.5	4.5
0.5	33	3	39	3	44.5	3.5	50.5	3.8	62	4.5
0.7	39	2.5	46.5	3	54	3.5	61	3.8	75	4.5
0.9	47	2.5	56	2.8	64	3	72	3.5	89	4
1	51	2.3	60	2.5	69	3	78	3.2	96	4

Liquid Flow	Liquid Pressure (BAR)/Air Consumption (M3/MIN) at these Air Pressures (BAR)									
	3 BAR		4 BAR		5 BAR		6 BAR		7 BAR	
	LPM	BAR	M3/MIN	BAR	M3/MIN	BAR	M3/MIN	BAR	M3/MIN	BAR
0.08	0.52	0.08	0.66	0.10	0.79	0.11	0.93	0.13	1.21	0.16
0.19	0.62	0.08	0.79	0.10	0.93	0.11	1.07	0.13	1.34	0.16
0.38	0.9	0.08	1.1	0.10	1.31	0.11	1.48	0.13	1.86	0.16
0.57	1.14	0.08	1.38	0.10	1.62	0.11	1.86	0.13	2.31	0.14
0.76	1.41	0.08	1.69	0.10	1.97	0.11	2.24	0.11	2.79	0.14
1.14	1.72	0.08	2.03	0.09	2.34	0.10	2.66	0.11	3.28	0.13
1.89	2.28	0.08	2.69	0.08	3.07	0.10	3.48	0.11	4.28	0.13
2.65	2.69	0.07	3.21	0.08	3.72	0.10	4.21	0.11	5.17	0.13
3.41	3.24	0.07	3.86	0.08	4.41	0.08	4.97	0.10	6.14	0.11
3.79	3.52	0.07	4.14	0.07	4.76	0.08	5.38	0.09	6.62	0.11

# In-Line Nozzles

## Standard Version

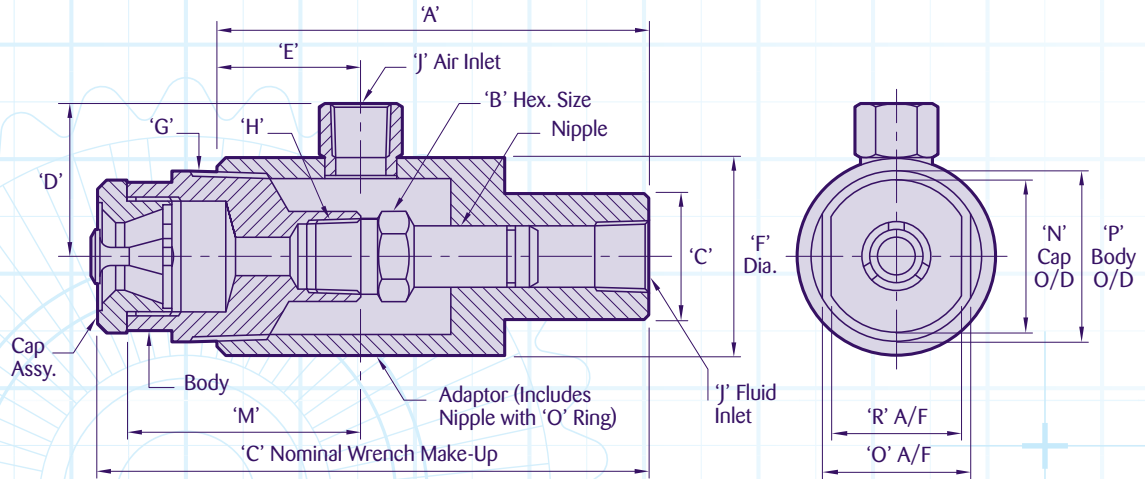

In-Line Nozzle/Adaptor Assembly Dimensions (inches/mm)

Dimension	W17875 W21122 Adaptor	W19868 19268 Adaptor	32555 32614 Adaptor	32554 32618 Adaptor	32668 32695 Adaptor	32740 32742 Adaptor	W19488 32742 Adaptor
A	—	5.25/133.35	5/127	4.75/120.7	4.75/120.7	3.55/90.2	3.55/90.2
B	—	—	0.87/22.2	0.63/15.9	0.63/15.9	0.5/12.7	0.5/12.7
C	—	—	6/152.4	5.75/146.1	5.62/142.8	4.25/108	4.25/108
D	—	1.88/47.63	1.75/44.5	1.56/39.6	1.56/39.6	1.28/32.6	1.28/32.6
E	—	2/50.8	1.75/44.5	2.29/58.4	2.29/58.4	1.5/38.1	1.5/38.1
F	—	2.5/63.5	2/50.8	1.63/41.3	1.63/41.3	1.13/28.6	1.13/28.6
L	—	—	1.5/38.1	1.25/31.8	1.25/31.8	0.75/19.1	0.75/19.1
M	3.25/82.55	2.75/69.88	2.35/59.7	2.12/53.9	2.13/54	1.5/38.1	1.5/38.1
N	2.13/53.98	1.63/41.28	1.37/34.7	1.11/28.3	0.87/22	0.74/18.8	0.74/18.8
O	1.81/46.02	1.44/36.49	1.25/31.8	1/25.4	0.75/19	0.63/15.9	0.88/22.4
P	2.38/60.33	1.9/48.26	1.66/42.2	1.31/33.4	1.05/26.7	0.84/21.3	1/25.4
R	2.06/52.37	1.63/41.28	1.37/34.9	1.13/28.6	0.87/22.2	0.75/19	0.63/16
G (NPTM)	2"	1½"	1¼"-11½"	1"-11½"	¾"-14	½"-14	½"
H (NPTF)	¾"	½"	½"-14	¼"-18	¼"-18	⅛"-27	⅛"
J (NPTF)	1"	¾"	½"-14	½"-14	½"-14	¼"-18	¼"
NIPPLE	—	—	32163	32617	32617	32743	32743

In-Line Nozzle Sizing Chart

Nominal Flow USGPM/LPM	Nozzle Assembly Reference Number	Dash Numbers For Material and Nominal Spray Angle			Cap Assembly		Optional Adaptor
		316 SS	Angle (°)	Min. Passage (inches/mm)	316 SS	440 HSS	
42/159	W17875	-1	100 (90-110)	0.22/5.6	17877	—	21122
		-2	50 (40-60)	0.24/6.1	707-97	—	
		-3	100 (90-110)	0.15/3.8	707-96	—	19268
25/94	W19868	-1	75 (65-85)	0.19/4.8	707-96	—	
		-2	50 (40-60)	0.24/6.1	707-11	707-26	
		-3	100 (90-110)	0.11/2.8	707-10	707-25	32614
15/56	32555	-1	75 (65-85)	0.14/3.6	707-11	707-26	
		-2	50 (40-60)	0.09/2.5	707-10	707-25	
		-3	100 (90-110)	0.07/1.7	707-12	707-27	
10/37	32554	-1	75 (65-85)	0.08/2.1	707-8	707-23	
		-2	50 (40-60)	0.09/2.5	707-7	707-22	32618
		-3	100 (90-100)	0.06/1.6	707-9	707-24	
4/15	32668	-1	75 (65-85)	0.07/1.7	707-5	707-20	
		-2	50 (40-60)	0.07/1.7	707-4	707-19	
		-3	100 (90-100)	0.07/1.7	707-6	707-21	32695
2.5/9.5	32740	-1	75 (65-85)	0.05/1.3	707-2	707-17	
		-2	50 (40-60)	0.05/1.3	707-1	707-16	32742
		-3	100 (90-100)	0.05/1.3	707-3	707-18	
1/3.8	32740	-4	75 (65-85)	0.02/0.64	707-93	—	
		-13	50 (40-60)	0.02/0.64	707-13	—	32742
		-5	100 (90-100)	0.02/0.64	707-29	—	
0.2/0.8	W19488	-3	100 (90-110)	0.02/0.64	707-13	—	32742
		-2	75 (65-85)	0.02/0.64	707-29	—	
		-4	50 (40-60)	0.02/0.64	707-93	—	

\* Higher flow rates can be achieved by increasing pressure.

**Carbide Lined Version**

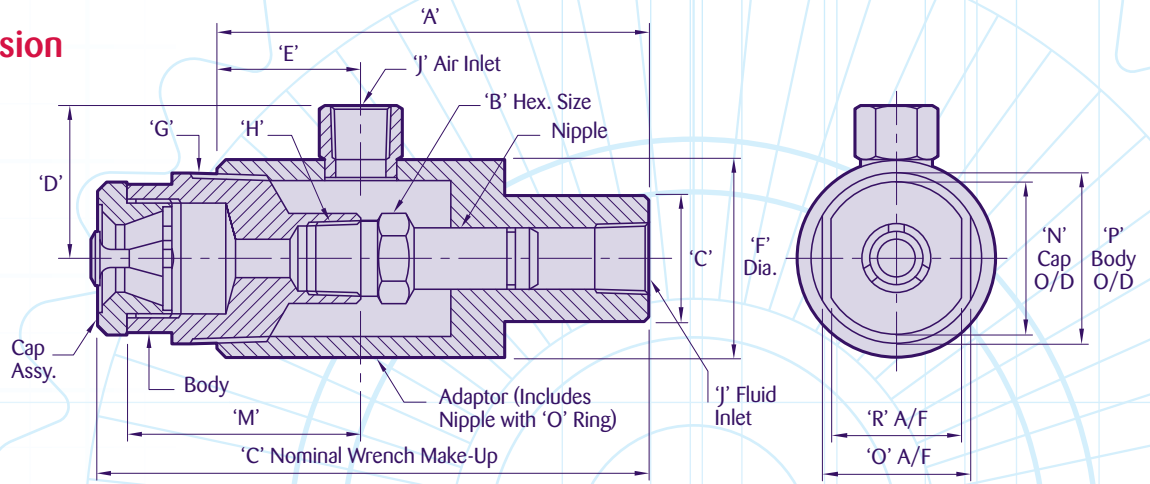

**Carbide Lined In-Line Nozzle/Adaptor Assembly Dimensions (inches/mm)**

Dimension	39144-All No's 32614 Adaptor	39185-All No's 32618 Adaptor	39195-All No's 32695 Adaptor	39225-All Nos 32695 Adaptor
A	5/127	4.75/120.7	4.75/120.7	4.75/120.7
B	0.87/22.2	0.63/15.9	0.63/15.9	0.5/12.7
C	6/152.4	5.9/150	5.9/150	0.76/109.2
D	1.75/44.5	1.56/39.6	1.56/39.6	1.28/32.6
E	1.75/44.5	2.3/58.4	2.3/58.4	1.5/38.1
F	2/50.8	1.63/41.3	1.63/41.3	1.13/28.6
L	1.5/38.1	1.25/31.8	1.25/31.8	0.75/19.1
M	2.35/59.7	2.12/53.9	2.12/53.9	1.5/38.1
N	1.56/39.5	1.25/31.8	1.02/25.8	0.8/20.3
O	1.37/34.9	1.13/28.6	0.87/22.2	0.72/18.3
P	1.87/47.4	1.49/37.9	1.18/30	0.93/23.6
R	1.37/34.9	1.13/28.6	0.87/22.2	0.72/18.3
G (NPTM)	1 1/4"-11 1/2"	1"-11 1/2"	3/4"-14	1/2"-14
H (NPTF)	1/2"-14	3/4"-18	1/4"-18	1/8"-27
J (NPTF)	1/2"-14	1/2"-14	1/2"-14	1/4"-18

**Carbide Lined In-Line Nozzle Sizing Chart**

Nominal Flow USGPM/LPM	Nozzle Assembly Reference Number	Pintle & Sleeve		Nominal Spray Angle	Min. Passage (inches/mm)	Cap Assembly		Optional Adaptor
		Tungsten	Nickel			Tungsten	Nickel	
15/56	39144	-2	-5	50 (40-60)	0.17/4.3	39138-1	39138-2	32614
		-1	-4	75 (65-85)	0.14/3.6			
		-3	-6	100 (90-110)	0.11/2.8			
10/37	39185	-2	-5	50 (40-60)	0.09/2.5	39184-1	39184-2	32618
		-1	-4	75 (65-85)	0.08/2.1			
		-3	-6	100 (90-100)	0.06/1.6			
4/15	39195	-2	-5	50 (40-60)	0.07/1.7	39197-1	39197-2	32695
		-1	-4	75 (65-85)	0.07/1.7			
		-3	-6	100 (90-100)	0.07/1.7			
2.5/9.5	39225	-2	-5	50 (40-60)	0.05/1.3	39226-1	39226-2	32742
		-1	-4	75 (65-85)	0.05/1.3			
		-3	-6	100 (90-100)	0.05/1.3			

\* Higher flow rates can be achieved by increasing pressure.

The standard thread for the Swirl-Air® Nozzle is NPT, however BSPT is available on request.

Contact our Helpline or your local distributor for further information  
Tel: +44 (151) 424 6821 or inside USA Toll Free: 1-800 Delavan  
E-mail: delavanspray@goodrich.com or sales@delavan.co.uk

# Swirl-Air® Product Technical Data

## In-Line Nozzles

### In-Line Nozzle P/N 17875 42 USGPM/159 LPM Max Flow

Liquid Flow	Liquid Pressure (PSI)/Air Consumption (SCFM) at these Air Pressures (PSI)									
	20 PSI		40 PSI		60 PSI		80 PSI		100 PSI	
	USGPM	PSI	SCFM	PSI	SCFM	PSI	SCFM	PSI	SCFM	PSI
9	20	95	35	183	45	313	57	438	68	—
12	22	93	39	175	51	283	64	380	77	—
18	37	75	51	150	61	263	74	358	93	475
24	54	63	67	125	85	218	96	283	112	398
30	73	50	90	100	106	183	120	223	133	333
36	96	38	115	83	132	158	157	168	160	280
42	123	25	147	75	163	130	—	—	—	—

Liquid Flow	Liquid Pressure (BAR)/Air Consumption (M3/MIN) at these Air Pressures (BAR)									
	1.4 BAR		2.8 BAR		4.1 BAR		5.5 BAR		7 BAR	
	LPM	BAR	M3/MIN	BAR	M3/MIN	BAR	M3/MIN	BAR	M3/MIN	BAR
34	1.38	2.69	2.41	5.17	3.10	8.85	3.93	12.39	4.69	—
45	1.52	2.63	2.69	4.96	3.52	8	4.41	10.76	5.31	—
68	2.55	2.12	3.52	4.25	4.21	7.43	5.10	10.12	6.41	13.45
91	3.72	1.77	4.62	3.54	5.86	6.16	6.62	8.00	7.72	11.26
114	5.03	1.42	6.21	2.83	7.31	5.17	8.28	6.30	9.17	9.42
136	6.62	1.06	7.93	2.34	9.10	4.46	10.83	4.74	11.03	7.93
159	8.48	0.71	10.14	2.12	11.24	3.68	—	—	—	—

### In-Line Nozzle P/N W19868 25 USGPM/94 LPM Max Flow

Liquid Flow	Liquid Pressure (PSI)/Air Consumption (SCFM) at these Air Pressures (PSI)									
	30 PSI		40 PSI		50 PSI		80 PSI		100 PSI	
	USGPM	PSI	SCFM	PSI	SCFM	PSI	SCFM	PSI	SCFM	PSI
5	20	116	26	149	32	183	50	283	62	—
10	27	91	34	121	41	150	62	240	75	—
15	32	68	43	93	51	120	75	197	90	250
20	43	52	51	72	60	93	85	154	102	195
25	54	35	63	53	72	73	99	128	117	166
30	62	17	72	34	82	51	112	102	132	136

Liquid Flow	Liquid Pressure (BAR)/Air Consumption (M3/MIN) at these Air Pressures (BAR)									
	2 BAR		2.8 BAR		3.5 BAR		5.5 BAR		7 BAR	
	LPM	BAR	M3/MIN	BAR	M3/MIN	BAR	M3/MIN	BAR	M3/MIN	BAR
19	1.38	3.29	1.79	4.22	2.21	5.18	3.45	8.01	4.28	0.00
37	1.86	2.58	2.34	3.43	2.83	4.25	4.28	6.80	5.17	0.00
56	2.41	1.93	2.97	2.63	3.52	3.40	5.17	5.58	6.21	7.08
76	2.97	1.47	3.52	2.04	4.14	2.63	5.86	4.36	7.03	5.52
94	3.72	0.99	4.34	1.50	4.97	2.07	6.83	3.63	8.07	4.70
114	4.28	0.48	4.97	0.96	5.66	1.44	7.72	2.89	9.10	3.85

### In-Line Nozzle P/N 32555 15 USGPM/56 LPM Max Flow

Liquid Flow	Liquid Pressure (PSI)/Air Consumption (SCFM) at these Air Pressures (PSI)									
	20 PSI		40 PSI		60 PSI		80 PSI		100 PSI	
	USGPM	PSI	SCFM	PSI	SCFM	PSI	SCFM	PSI	SCFM	PSI
5	19	50	24	65	28	80	42	126	51	156
6	23	48	28	63	32	78	46	123	55	154
7	27	44	32	58	37	74	52	120	62	151
8	30	41	36	55	41	70	58	114	68	143
9	33	38	40	52	46	66	63	108	75	137
10	37	34	44	48	50	62	67	103	80	130
11	41	32	48	45	54	58	73	98	86	124
12	45	29	52	42	59	55	82	93	96	118
13	48	27	56	39	63	51	85	88	100	112
14	52	24	60	36	68	48	91	84	106	107
15	56	22	65	34	73	45	98	79	114	102

Liquid Flow	Liquid Pressure (BAR)/Air Consumption (M3/MIN) at these Air Pressures (BAR)									
	1.4 BAR		2.8 BAR		4.1 BAR		5.5 BAR		7 BAR	
	LPM	BAR	M3/MIN	BAR	M3/MIN	BAR	M3/MIN	BAR	M3/MIN	BAR
19	1.31	1.42	1.66	1.84	1.93	2.27	2.9	3.57	3.52	4.42
23	1.59	1.36	1.93	1.78	2.21	2.21	3.17	3.48	3.79	4.36
27	1.86	1.25	2.21	1.64	2.55	2.10	3.59	3.40	4.28	4.28
30	2.07	1.16	2.48	1.56	2.83	1.98	4	3.23	4.69	4.05
34	2.28	1.08	2.76	1.47	3.17	1.87	4.34	3.06	5.17	3.88
37	2.55	0.96	3.03	1.36	3.45	1.76	4.62	2.92	5.52	3.68
42	2.83	0.91	3.31	1.27	3.72	1.64	5.03	2.78	5.93	3.51
45	3.1	0.82	3.59	1.19	4.07	1.56	5.66	2.63	6.62	3.34
49	3.31	0.76	3.86	1.10	4.34	1.44	5.86	2.49	6.90	3.17
53	3.59	0.68	4.14	1.02	4.69	1.36	6.28	2.38	7.31	3.03
56	3.86	0.62	4.48	0.96	5.03	1.27	6.76	2.24	7.86	2.89

### In-Line Nozzle P/N 32554-1 10 USGPM/38 LPM Max Flow

Liquid Flow	Liquid Pressure (PSI)/Air Consumption (SCFM) at these Air Pressures (PSI)									
	30 PSI		40 PSI		50 PSI		80 PSI		100 PSI	
	USGPM	PSI	SCFM	PSI	SCFM	PSI	SCFM	PSI	SCFM	PSI
2	14	31	18	40	22	48	33	72	41	87
3	20	29	25	38	29	46	42	70	51	86
4	26	26	31	36	36	44	52	68	63	85
5	31	24	38	33	44	41	61	66	70	83
6	38	21	45	29	51	38	69	63	82	80
7	44	18	51	26	59	34	78	58	92	74
8	51	16	59	23	67	30	87	54	102	70
9	59	13	68	20	75	27	99	50	114	65
10	68	11	76	18	85	25	107	46	123	60

Liquid Flow	Liquid Pressure (BAR)/Air Consumption (M3/MIN) at these Air Pressures (BAR)									
	2 BAR		2.8 BAR		3.5 BAR		5.5 BAR		7 BAR	
	LPM	BAR	M3/MIN	BAR	M3/MIN	BAR	M3/MIN	BAR	M3/MIN	BAR
8	0.97	0.88	1.24	1.13	1.52	1.36	2.28	2.04	2.83	2.46
11	1.38	0.82	1.72	1.08	2	1.3	2.9	1.98	3.52	2.44
15	1.79	0.74	2.14	1.02	2.48	1.25	3.59	1.93	4.34	2.41
19	2.14	0.68	2.62	0.93	3.03	1.16	4.21	1.87	4.83	2.35
23	2.62	0.59	3.1	0.82	3.52	1.08	4.76	1.78	5.66	2.27
27	3.03	0.51	3.52	0.74	4.07	0.96	5.38	1.64	6.34	2.1
30	3.52	0.45	4.07	0.65	4.62	0.85	6	1.53	7.03	1.98
34	4.07	0.37	4.69	0.57	5.17	0.76	6.83	1.42	7.86	1.84
38	4.69	—	5.24	—	5.86	—	7.38	—	8.48	—

**In-Line Nozzle P/N 32668-1 4 USGPM/15 LPM Max Flow**

Liquid Flow		Liquid Pressure (PSI)/Air Consumption (SCFM) at these Air Pressures (PSI)										Liquid Flow		Liquid Pressure (BAR)/Air Consumption (M3/MIN) at these Air Pressures (BAR)									
		30 PSI		40 PSI		50 PSI		80 PSI		100 PSI				2 BAR		2.8 BAR		3.5 BAR		5.5 BAR		7 BAR	
USGPM	PSI	SCFM	PSI	SCFM	PSI	SCFM	PSI	SCFM	PSI	SCFM	PSI	SCFM	LPM	BAR	M3/MIN	BAR	M3/MIN	BAR	M3/MIN	BAR	M3/MIN	BAR	M3/MIN
0.33	15	16	21	21	27	25	45	38	57	47	1	1.03	0.45	1.45	0.59	1.86	0.71	3.10	1.08	3.93	1.33		
0.5	18	16	24	20	30	24	49	37	61	46	2	1.24	0.44	1.66	0.57	2.07	0.68	3.38	1.05	4.21	1.30		
0.66	19	15	25	19	32	23	51	36	64	45	3	1.31	0.41	1.72	0.54	2.21	0.65	3.52	1.02	4.41	1.27		
1	24	13	32	17	38	21	59	34	73	42	4	1.66	0.37	2.21	0.48	2.62	0.59	4.07	0.96	5.03	1.19		
2	36	8	45	11	53	15	77	26	93	33	8	2.48	0.23	3.10	0.31	3.66	0.42	5.31	0.74	6.41	0.93		
3	50	5	60	7	69	10	95	19	113	25	11	3.45	0.14	4.14	0.20	4.76	0.28	6.55	0.54	7.79	0.71		
3.5	60	3	69	6	78	8	105	16	124	22	13	4.14	0.08	4.76	0.17	5.38	0.23	7.24	0.45	8.55	0.62		
4	70	1	79	5	88	7	116	14	135	20	15	4.83	0.03	5.45	0.14	6.07	0.20	8	0.40	9.31	0.57		

**In-Line Nozzle P/N 32740-1 2.5 USGPM/9.5 LPM Max Flow**

Liquid Flow		Liquid Pressure (PSI)/Air Consumption (SCFM) at these Air Pressures (PSI)										Liquid Flow		Liquid Pressure (BAR)/Air Consumption (M3/MIN) at these Air Pressures (BAR)									
		30 PSI		40 PSI		50 PSI		80 PSI		100 PSI				2 BAR		2.8 BAR		3.5 BAR		5.5 BAR		7 BAR	
USGPM	PSI	SCFM	PSI	SCFM	PSI	SCFM	PSI	SCFM	PSI	SCFM	PSI	SCFM	LPM	BAR	M3/MIN	BAR	M3/MIN	BAR	M3/MIN	BAR	M3/MIN	BAR	M3/MIN
0.33	17	8.5	23	11	29	13	47	20.5	59	25	1	1.17	0.24	1.59	0.31	2	0.37	3.24	0.58	4.07	0.71		
0.5	19	7.5	26	10	33	12.5	50	19.5	65	24	2	1.31	0.21	1.79	0.28	2.28	0.35	3.45	0.55	4.48	0.68		
0.66	20	7	27	9.5	35	11.5	53	19	69	23	3	1.38	0.20	1.86	0.27	2.41	0.33	3.66	0.54	4.76	0.65		
1	24	5.5	32	7.5	39	10	61	17	76	21	4	1.66	0.16	2.21	0.21	2.69	0.28	4.21	0.48	5.24	0.59		
1.5	28	-	36	5.5	45	7.5	70	14	86	18	6	1.93	-	2.48	0.16	3.10	0.21	4.83	0.40	5.93	0.51		
2	30	-	39	-	48	5.5	75	11	92	15	8	2.07	-	2.69	-	3.31	0.16	5.17	0.31	6.34	0.42		
2.5	32	-	42	-	51	-	79	8	97	12	9.5	2.21	-	2.90	-	3.52	-	5.45	0.23	6.69	0.34		

**In-Line Nozzle P/N 32740-4 1 USGPM/3.8 LPM Max Flow**

Liquid Flow		Liquid Pressure (PSI)/Air Consumption (SCFM) at these Air Pressures (PSI)										Liquid Flow		Liquid Pressure (BAR)/Air Consumption (M3/MIN) at these Air Pressures (BAR)									
		30 PSI		40 PSI		50 PSI		80 PSI		100 PSI				2 BAR		2.8 BAR		3.5 BAR		5.5 BAR		7 BAR	
USGPM	PSI	SCFM	PSI	SCFM	PSI	SCFM	PSI	SCFM	PSI	SCFM	PSI	SCFM	LPM	BAR	M3/MIN	BAR	M3/MIN	BAR	M3/MIN	BAR	M3/MIN	BAR	M3/MIN
0.2	27	3.5	36.5	4.6	46	5.5	74	8.5	92	10.5	0.8	1.86	0.10	2.52	0.13	3.17	0.16	5.10	0.24	6.34	0.30		
0.3	27.5	3.0	37.5	3.5	47	4.5	75.8	7.5	95.5	9	2	1.90	0.08	2.59	0.10	3.24	0.13	5.23	0.21	6.59	0.25		
0.4	28	2.5	38	3	47.6	4	76.5	6.5	96	8	1.5	1.93	0.07	2.62	0.08	3.28	0.11	5.28	0.18	6.62	0.23		
0.5	28.5	2.0	38.5	2.5	48	3.5	77.5	5.5	97	7	1.9	1.97	0.06	2.66	0.07	3.31	0.10	5.34	0.16	6.69	0.20		
0.6	29	1.5	39	2.0	48.5	3.0	78	5	97.5	6.8	2.3	2	0.04	2.69	0.06	3.34	0.08	5.38	0.14	6.72	0.19		
0.7	29.2	1.2	39.2	1.8	48.8	2.5	78.5	4.5	98	5.5	2.7	2.01	0.03	2.70	0.05	3.37	0.07	5.41	0.13	6.76	0.16		
0.8	29.4	1	39.4	1.5	49	2.2	79	4	98.4	5	3	2.03	0.03	2.72	0.04	3.38	0.06	5.45	0.11	6.79	0.14		
0.9	29.6	-	39.8	1.2	49.2	2	79.2	3.5	98.6	4.5	3.4	2.04	-	2.74	0.03	3.39	0.06	5.46	0.10	6.80	0.13		
1	29.8	-	40	1	49.4	1.5	79.4	3	99	4	3.8	2.06	-	2.76	0.03	3.41	0.04	5.48	0.08	6.83	0.11		

**In-Line Nozzle P/N 19488 0.2 USGPM/0.8 LPM Max Flow**

Liquid Flow		Liquid Pressure (PSI)/Air Consumption (SCFM) at these Air Pressures (PSI)										Liquid Flow		Liquid Pressure (BAR)/Air Consumption (M3/MIN) at these Air Pressures (BAR)									
		50 PSI		60 PSI		70 PSI		80 PSI		100 PSI				3 BAR		4 BAR		5 BAR		5.5 BAR		7 BAR	
USGPM	PSI	SCFM	PSI	SCFM	PSI	SCFM	PSI	SCFM	PSI	SCFM	PSI	SCFM	LPM	BAR	M3/MIN	BAR	M3/MIN	BAR	M3/MIN	BAR	M3/MIN	BAR	M3/MIN
0.02	7.5	3	9.5	3.5	11.5	4	13.5	4.5	17.5	5.5	0.08	0.52	0.08	0.66	0.10	0.79	0.11	0.93	0.13	1.21	0.16		
0.05	9	3	11.5	3.5	13.5	4	15.5	4.5	19.5	5.5	0.19	0.62	0.08	0.79	0.10	0.93	0.11	1.07	0.13	1.34	0.16		
0.1	13	3	16	3.5	19	4	21.5	4.5	27	5.5	0.38	0.90	0.08	1.10	0.10	1.31	0.11	1.48	0.13	1.86	0.16		
0.15	16.5	3	20	3.5	23.5	4	27	4.5	33.5	5	0.57	1.14	0.08	1.38	0.10	1.62	0.11	1.86	0.13	2.31	0.14		
0.2	20.5	3	24.5	3.5	28.5	3.8	32.5	4	40.5	5	0.76	1.41	0.08	1.69	0.10	1.97	0.11	2.24	0.11	2.79	0.14		
0.3	25	3	29.5	3.3	34	3.5	38.5	4	47.5	4.5	1.14	1.72	0.08	2.03	0.09	2.34	0.10	2.66	0.11	3.28	0.13		
0.5	33	3	39	3	44.5	3.5	50.5	3.8	62	4.5	1.89	2.28	0.08	2.69	0.08	3.07	0.10	3.48	0.11	4.28	0.13		
0.7	39	2.5	46.5	3	54	3.5	61	3.8	75	4.5	2.65	2.69	0.07	3.21	0.08	3.72	0.10	4.21	0.11	5.17	0.13		
0.9	47	2.5	56	2.8	64	3	72	3.5	89	4	3.41	3.24	0.07	3.86	0.08	4.41	0.08	4.97	0.10	6.14	0.11		
1	51	2.3	60	2.5	69	3	78	3.2	96	4	3.79	3.52	0.07	4.14	0.07	4.76	0.08	5.38	0.09	6.62	0.11		

Dotted line represents limit of maximum recommended flow rate

# Swirl-Air® Nozzles

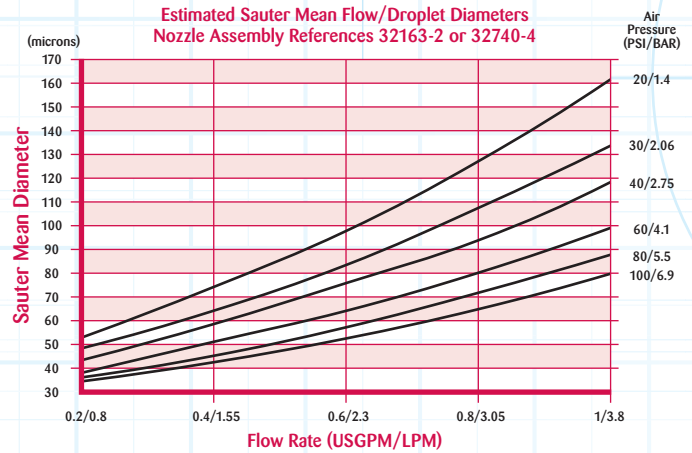
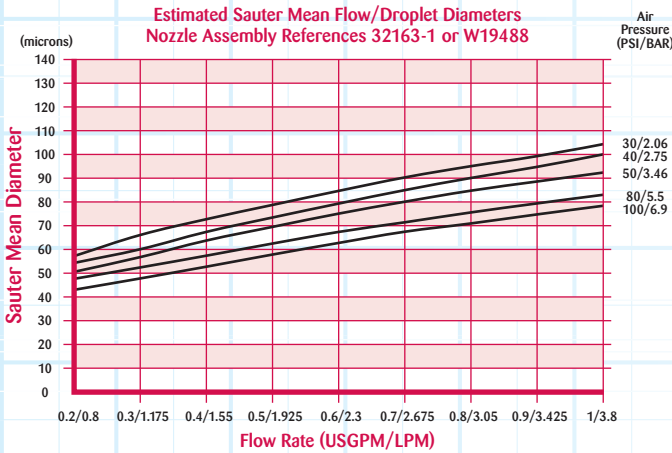
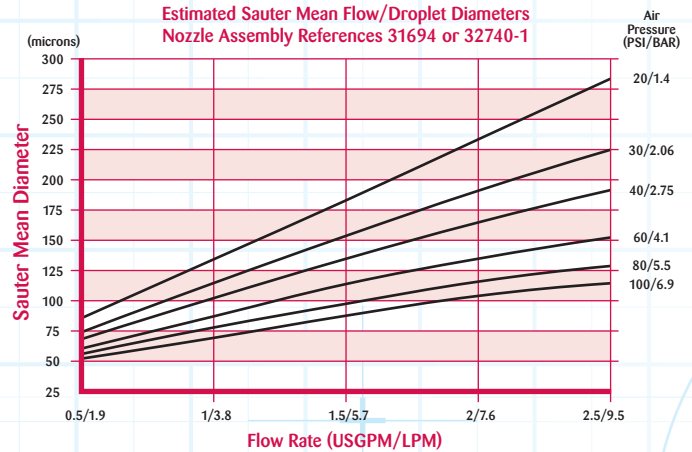
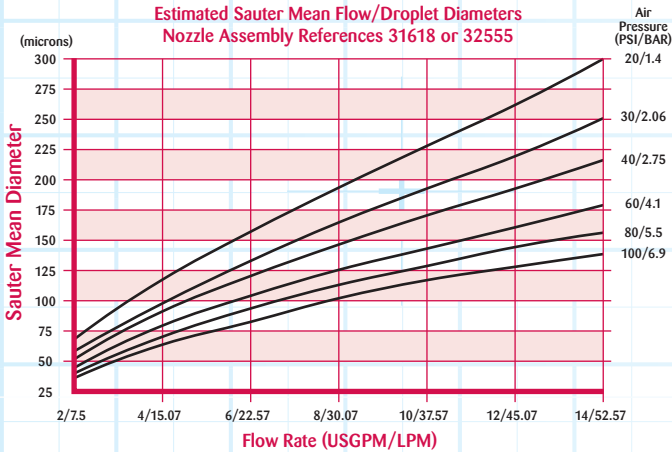
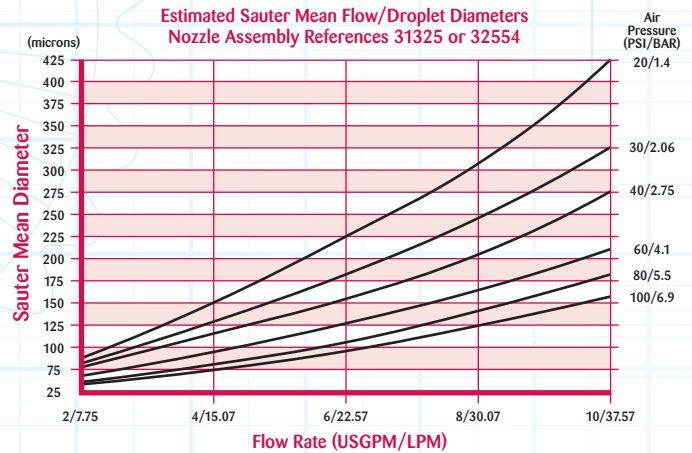
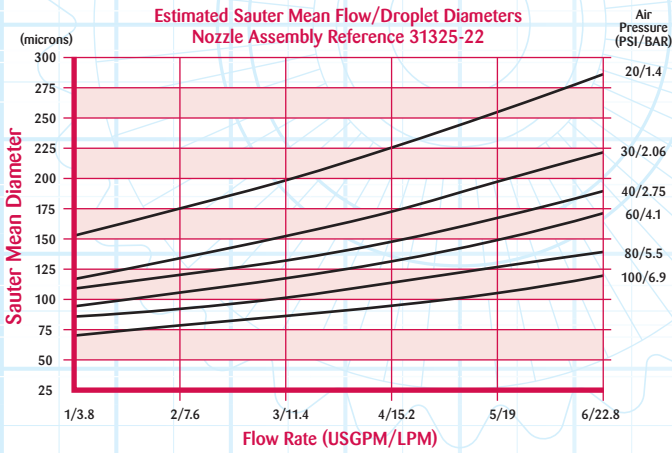
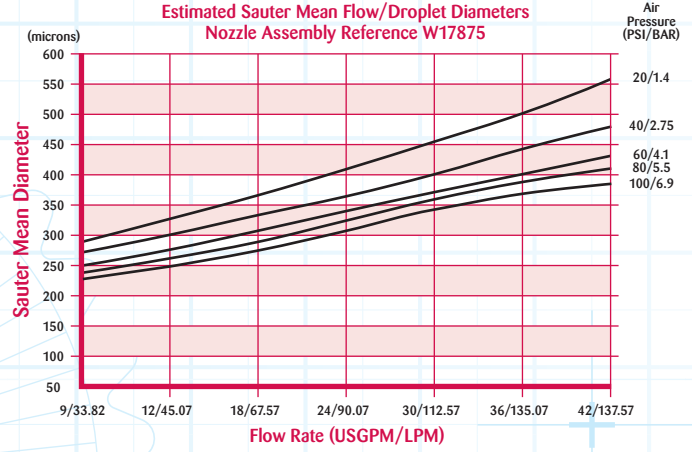
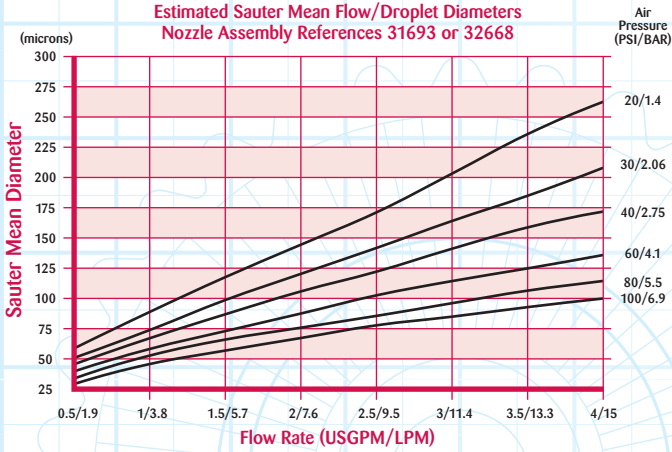

## We Don't Just Supply the Nozzles...

Delavan's extensive experience goes beyond just the nozzle with a full range of engineered support for spray lances.

Delavan offers a variety of production services to best meet your needs. For new systems, we will handle each stage of development from preliminary design to servicing the product. Delavan can also enhance current designs or simply manufacture products from existing designs.

We can provide cooled or heated lances, support special mounting flanges, by-pass or purge systems to meet every industry standard.

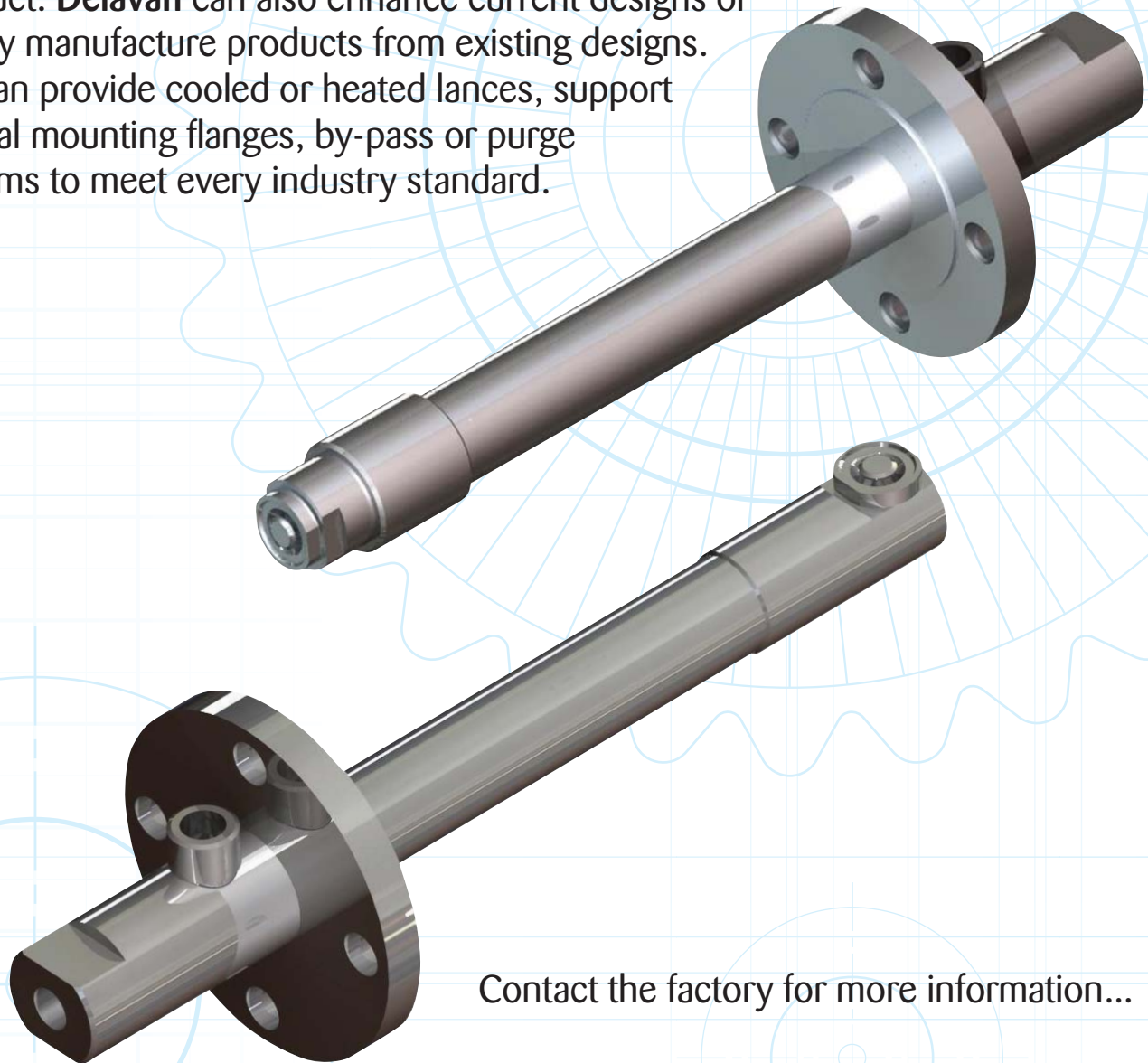

Contact the factory for more information...

Contact our Helpline or your local distributor for further information  
Tel: +44 (151) 424 6821 or inside USA Toll Free: 1-800 Delavan  
E-mail: [delavanspray@goodrich.com](mailto:delavanspray@goodrich.com) or [sales@delavan.co.uk](mailto:sales@delavan.co.uk)

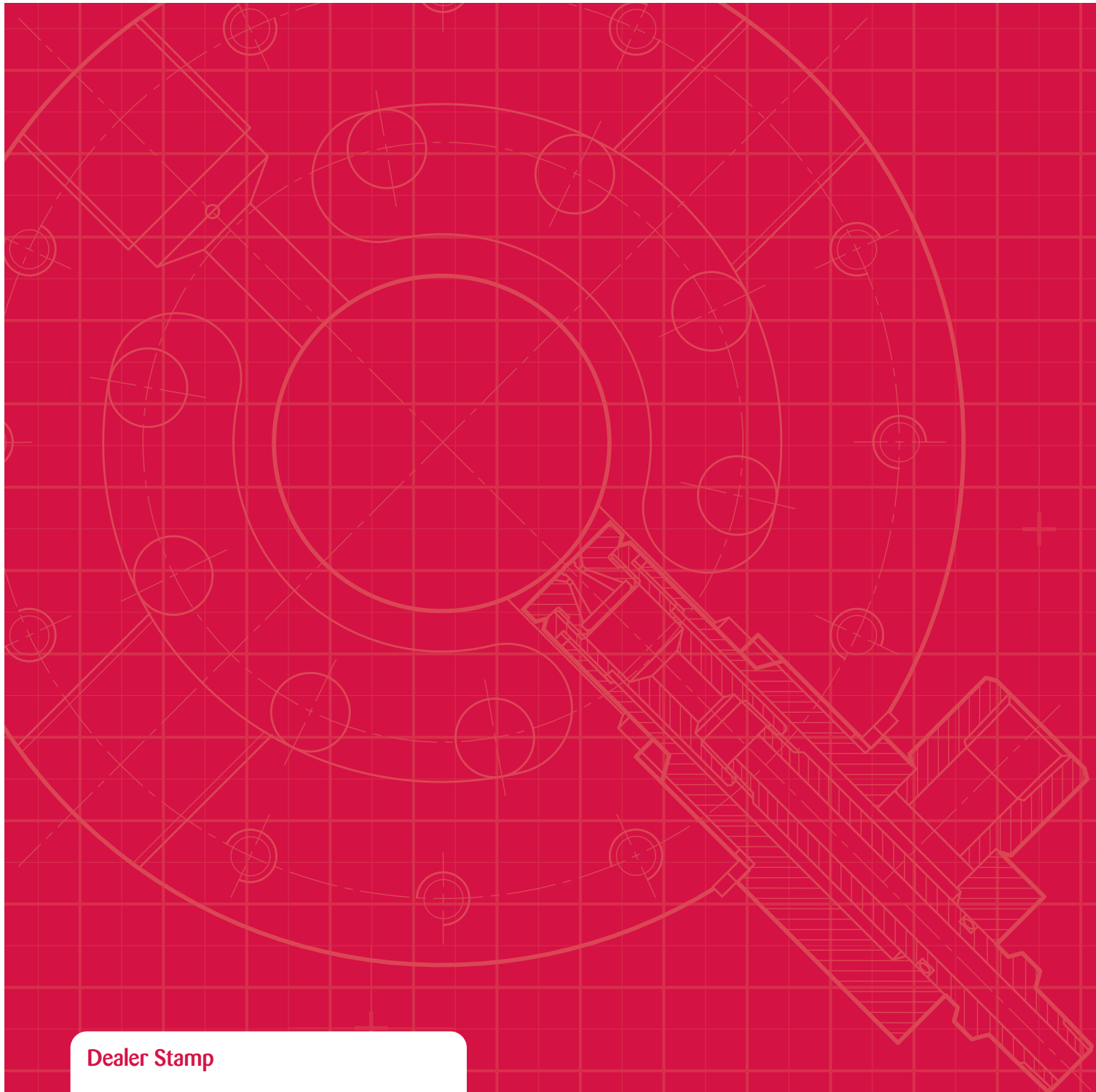

Dealer Stamp

Details of all our products are available  
on our website at [www.delavan.co.uk](http://www.delavan.co.uk)

Delavan Ltd, Gorse Lane, Widnes, Cheshire WA8 ORJ, UK  
Telephone: +44 (0)151 424 6821 Fax: +44 (0)151 495 1043  
Inside USA Toll Free: 1-800 Delavan  
e-mail: [sales@delavan.co.uk](mailto:sales@delavan.co.uk) or [delavanspray@goodrich.com](mailto:delavanspray@goodrich.com)

Delavan, Swirl-Air and the Goodrich Stripes logo are registered trademarks of Delavan Spray Technologies and the Goodrich Corporation respectively ©Delavan Spray Technologies 2011.  
All materials are the intellectual property of Goodrich and cannot be used without Goodrich's consent.

An ISO 9001:2000 Registered Company

